

Long Distance Wireless Charger

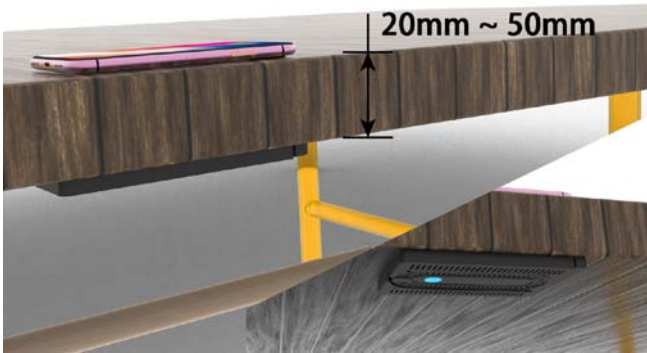

QB-21

7.5W/5W/10W
Stealth Wireless Charger

QB-21 is a Qi compatible wireless charger designed for charging mobile phones through 20~50mm thickness non-metallic solid materials such as wood, plastic, glass, and granite. It can support 5W Qi BPP standard, 7.5W Apple fast charging and 10W Samsung Fast Charging (SFC).

Key Features:

- Compatible with Qi-BPP 5W, iPhone 7.5W and Samsung 10W
- Support all Qi standard mobile phones
- Used for 20~50mm charging distance through non-metallic solid material between mobile phone and the charger available
- Easy installation
- Magnet collector increases the efficiency and speed of charging.
- Over-current/ Over-temperature/ Over-voltage and FOD protection
- FCC/CE certified

Specification

Power Input Interface	DC Jack $\phi 3.5 * \phi 1.35$
Input Power Requirement	DC: 19V 0.94A
Charging Power	5W 、 7.5W 、 10W (max.), delivery to the phone
Supported Protocol	Compatible with Qi-BPP, iPhone Fast Charging, Samsung Fast Charging
Standby Power	<0.2W
Charging Distance	20~50mm
Horizontal Freedom	+/- 8 mm
Typical Efficiency	84% @ 30mm (iPhone 8P)
Operation frequency	115~150KHz
Coil Type	Litz wire wound with ferrite
Operation Environment	0°C ~ 40°C (32°F ~ 104°F) 15 ~ 85% RH (Non-dewing)
Storage Environment	-20°C ~ 70°C (-4°F ~ 158°F) 5 ~ 95% RH (Non-dewing)

Long Distance Wireless Charger

Mechanical Specification:

Outline Dimension 154.0 mm (l) x 110.4 mm (w) x 10.7 mm (h)

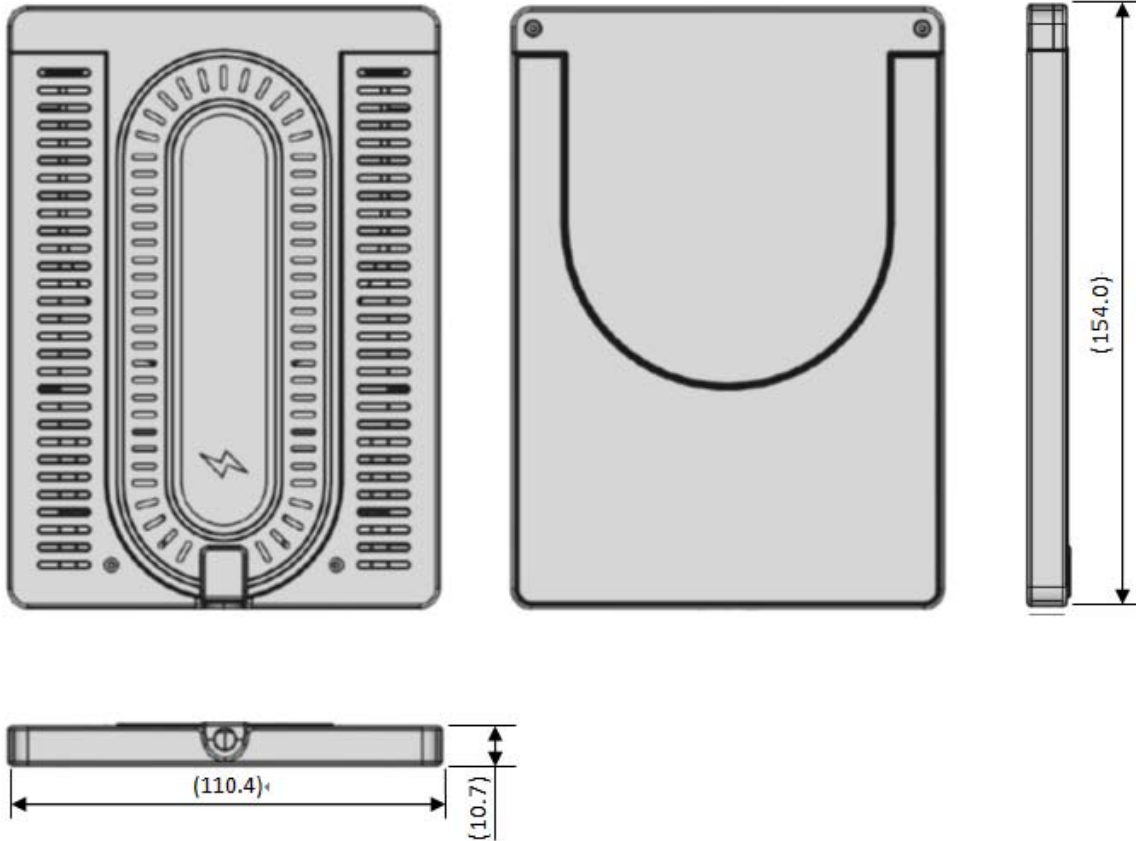

Magnet Collector Size 120 mm diameter circular, 1.50mm thickness

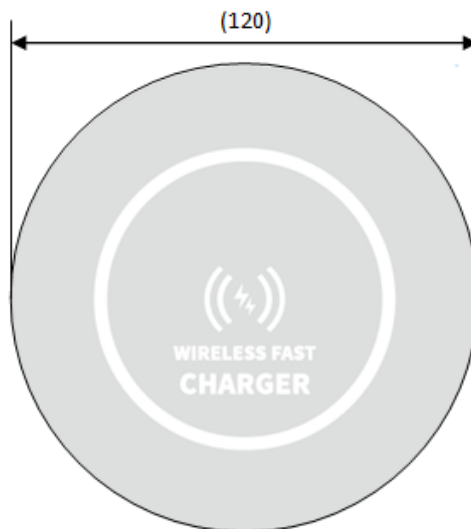

Unit: mm